

Ue = 7-9 V Gleichspannung oder
Ue = 5-6 V Wechselspannung

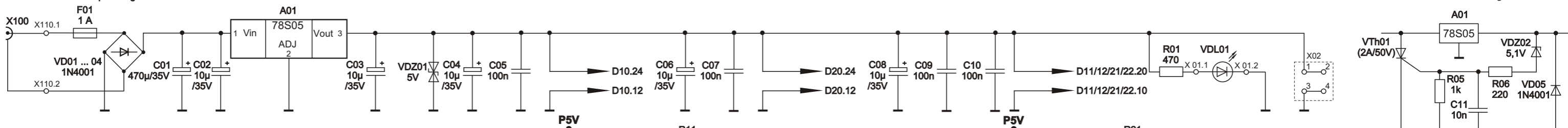

parallele Schnittstelle

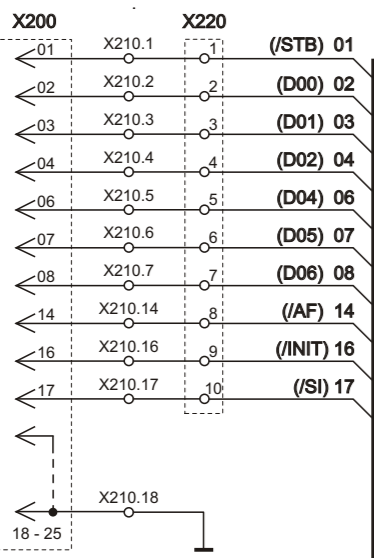

Adressierung

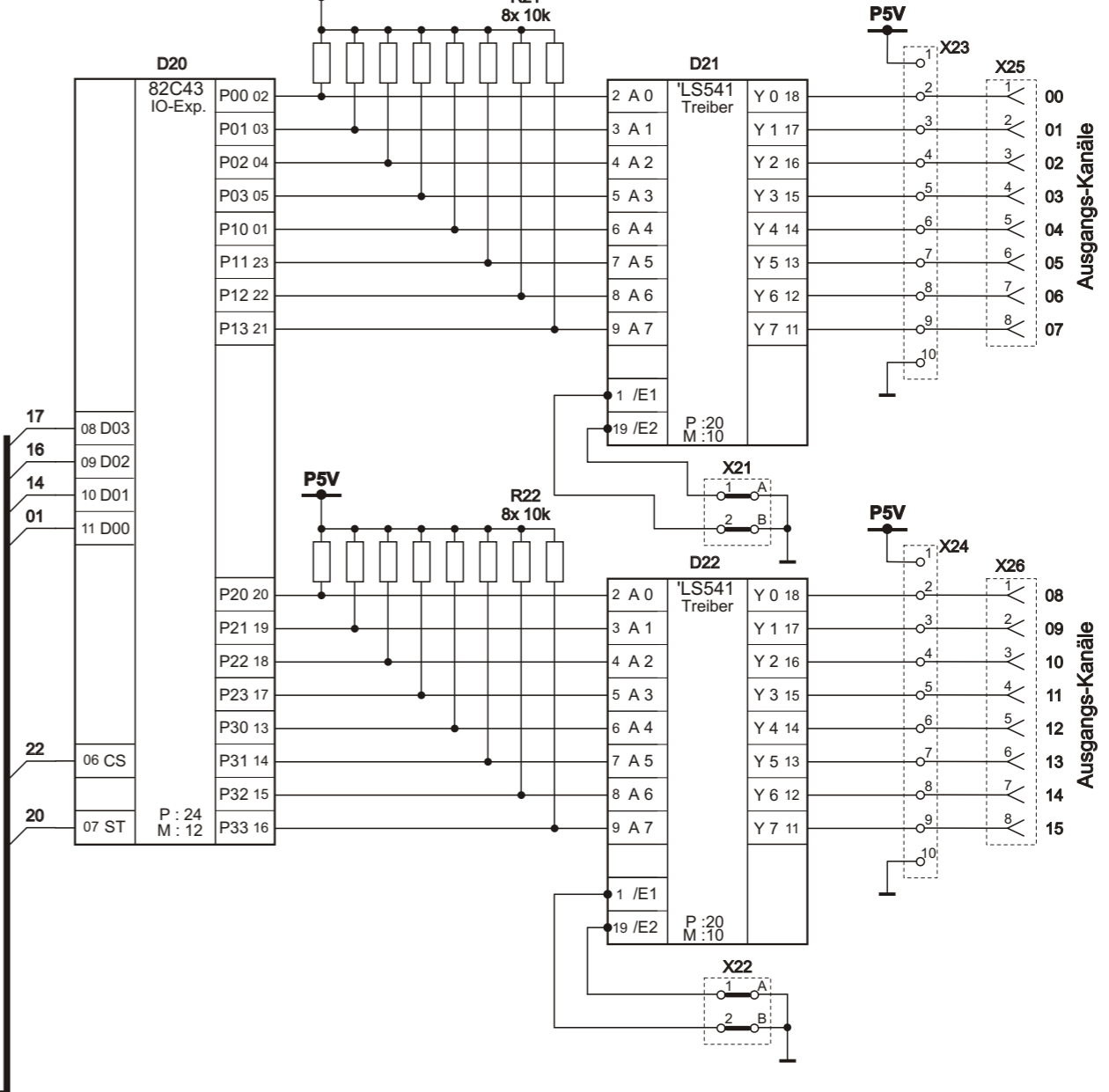
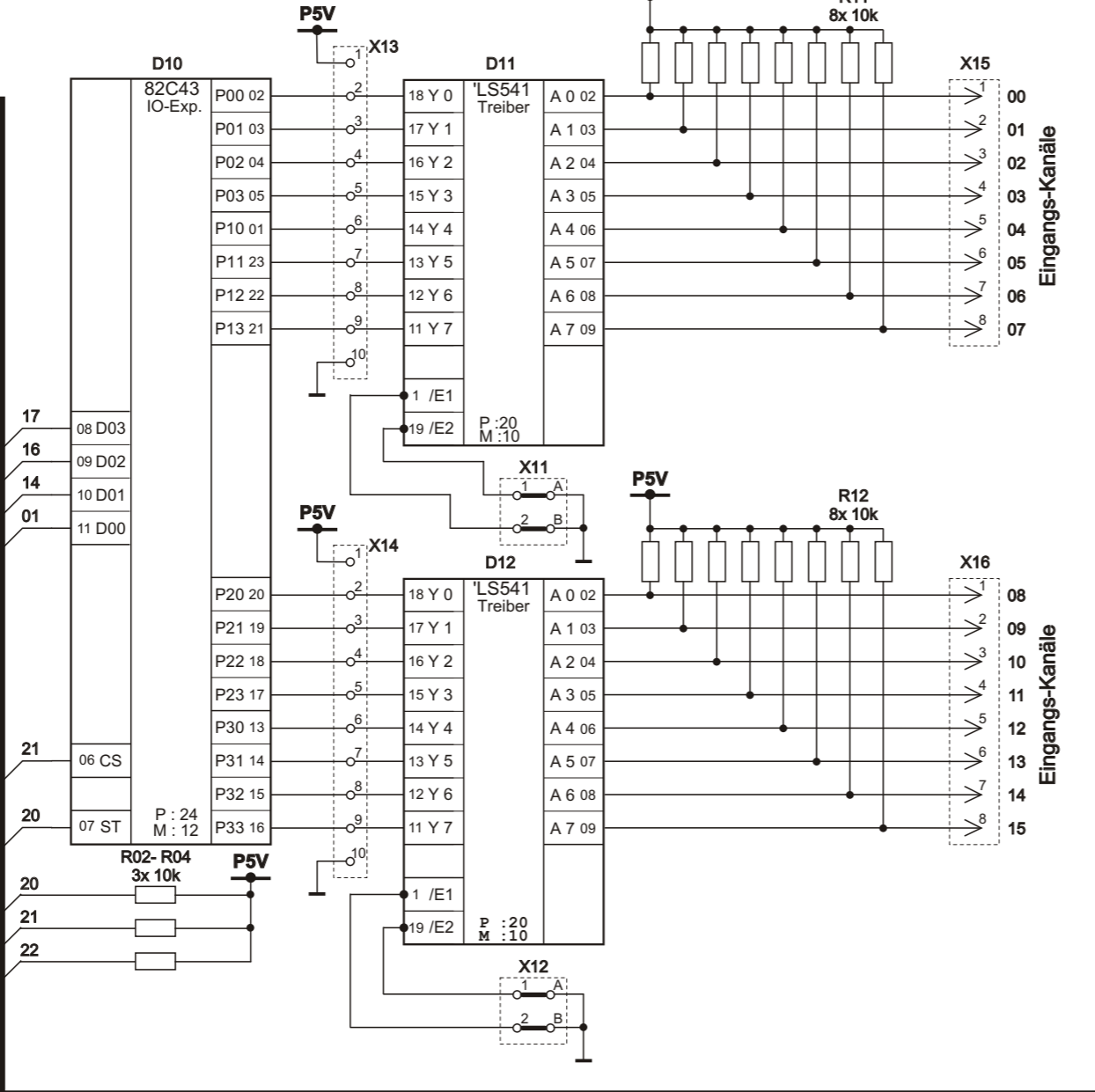
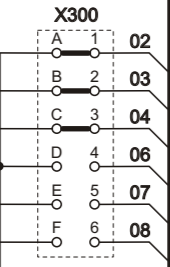

alternative Schutzschaltung für VDZ01

